



**klauzúrna práca**

# **PAPIEROVÝ NÁBYTOK**

Frederik Dedík / ADE / 2017

01.

**IDEA**

○ **využiť minimum materiálu**

○ **využiť formát B1 (recyklácia káp U16)**

○ **nízke odpočinkové kreslo z lepenky**

○ **suché spoje, jednoduché zkladanie  
z flatpackého balenia**

02.

# ERGONÓMIA

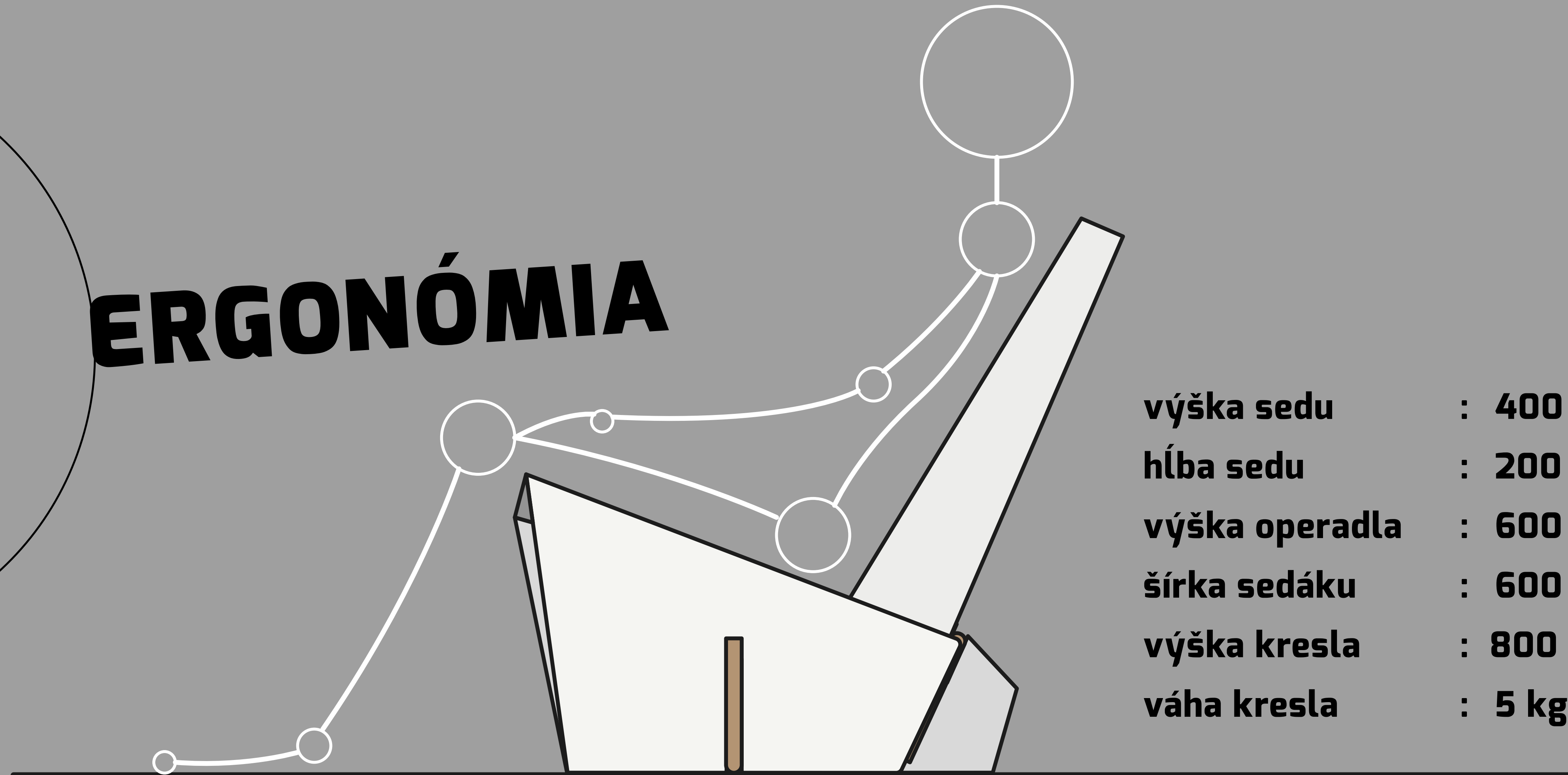

# POHĽADY

03.

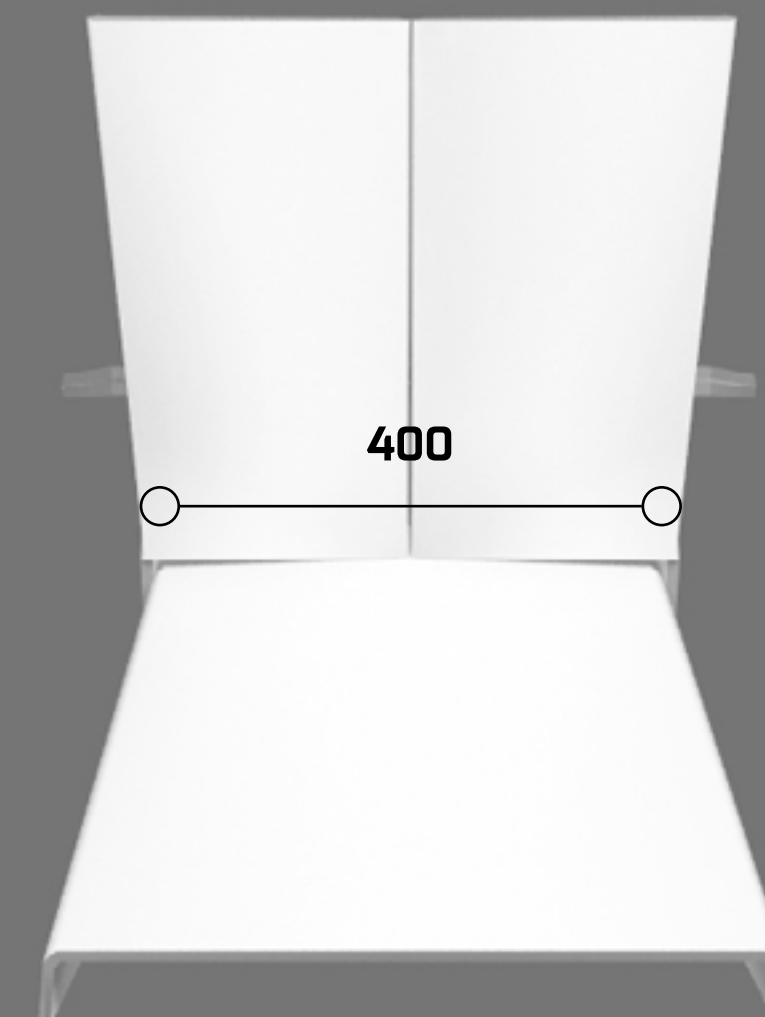
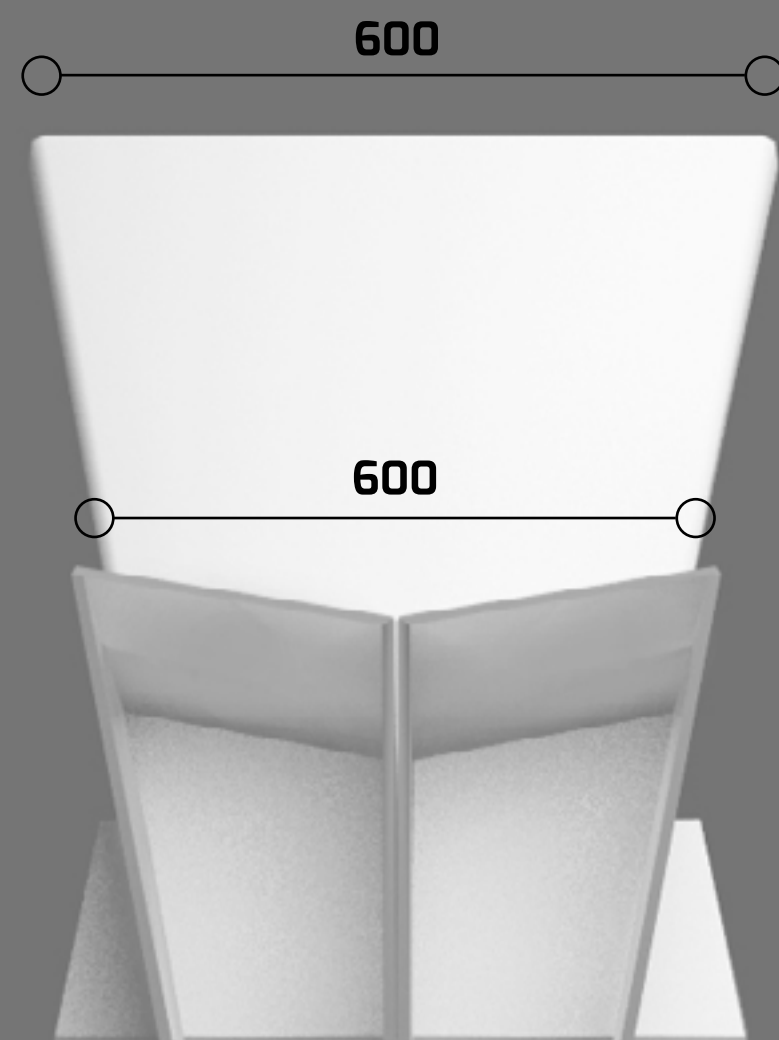
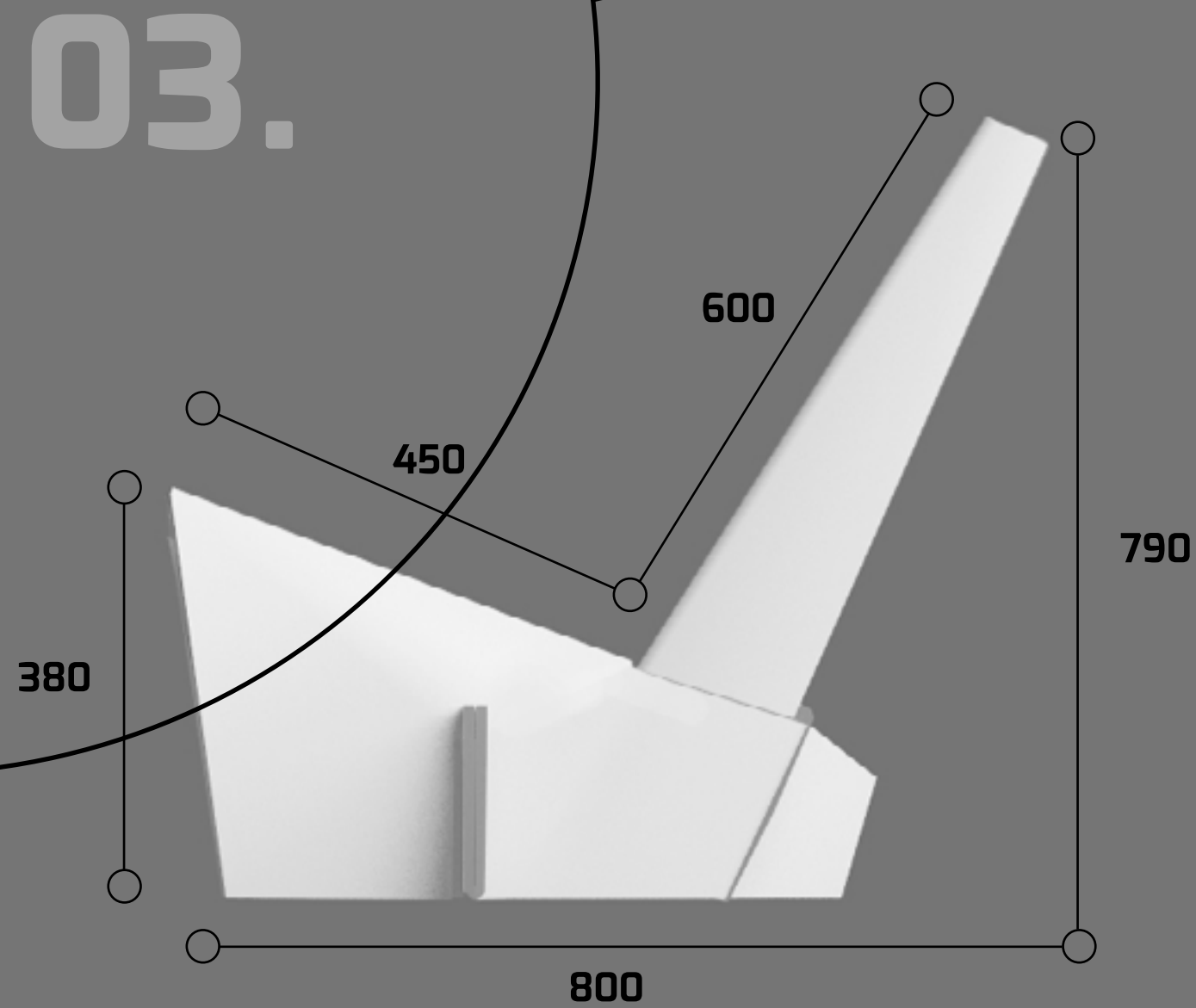

tvoroslovie vychádza  
z geometrie sedenia  
a z maximálneho  
využitia formátu B1

04.

# STABILITA

**váhu tela podpierajú  
previazané rebrá  
vovnútri kresla**



05.

# KONŠTRUKCIA

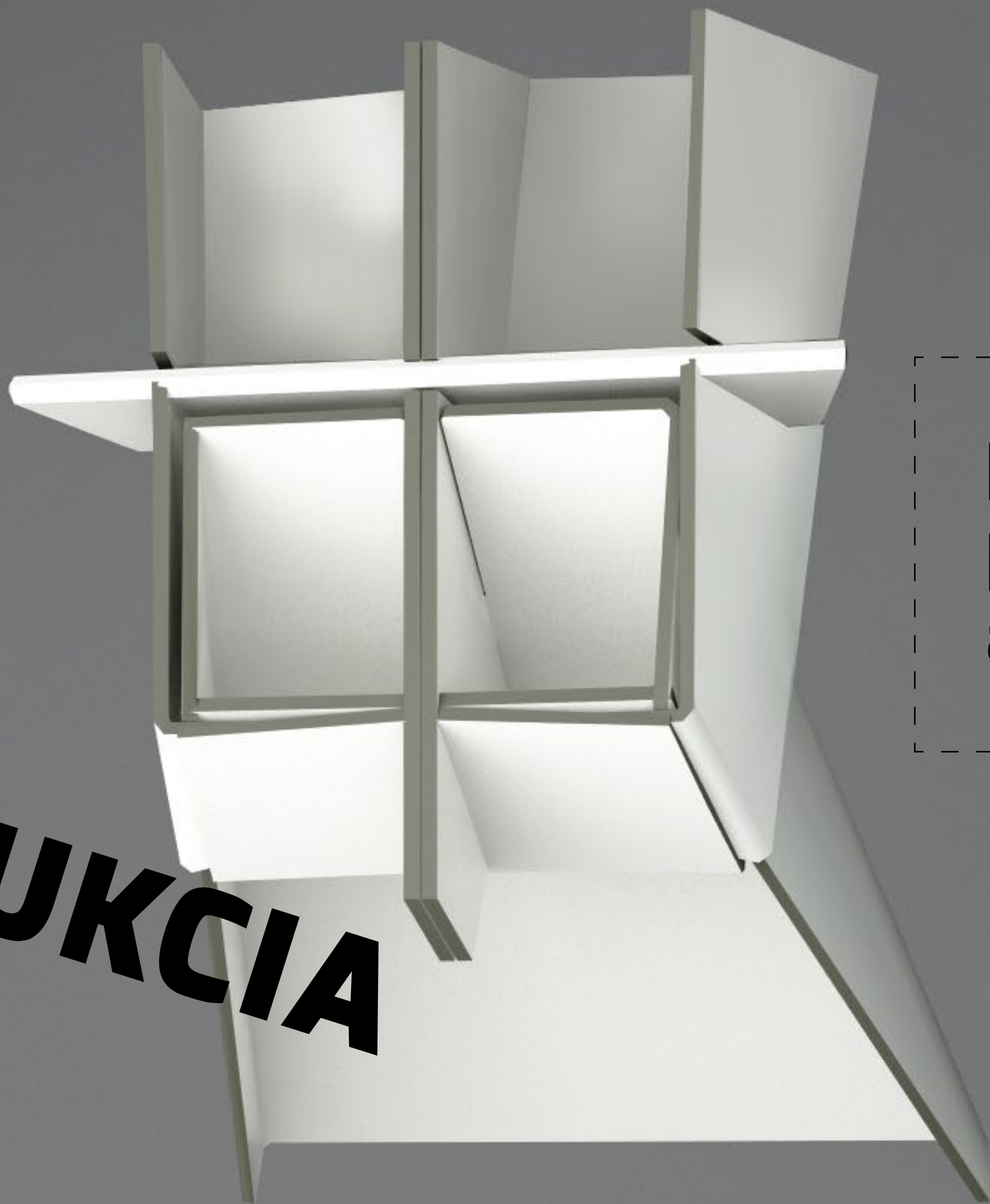

pohľad na štruktúru  
previazania vertikál  
a horizontál

06.

**DIELY**

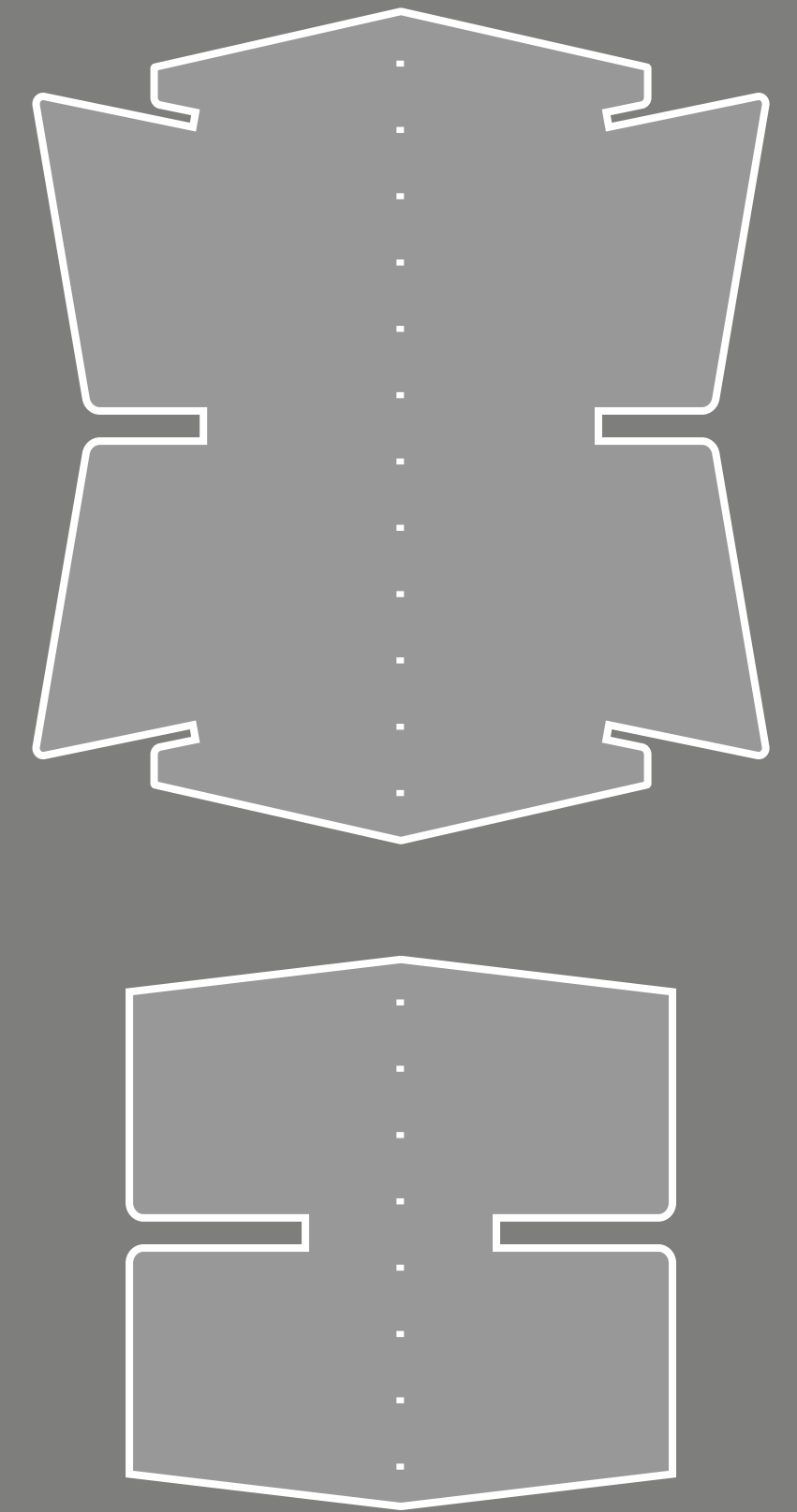
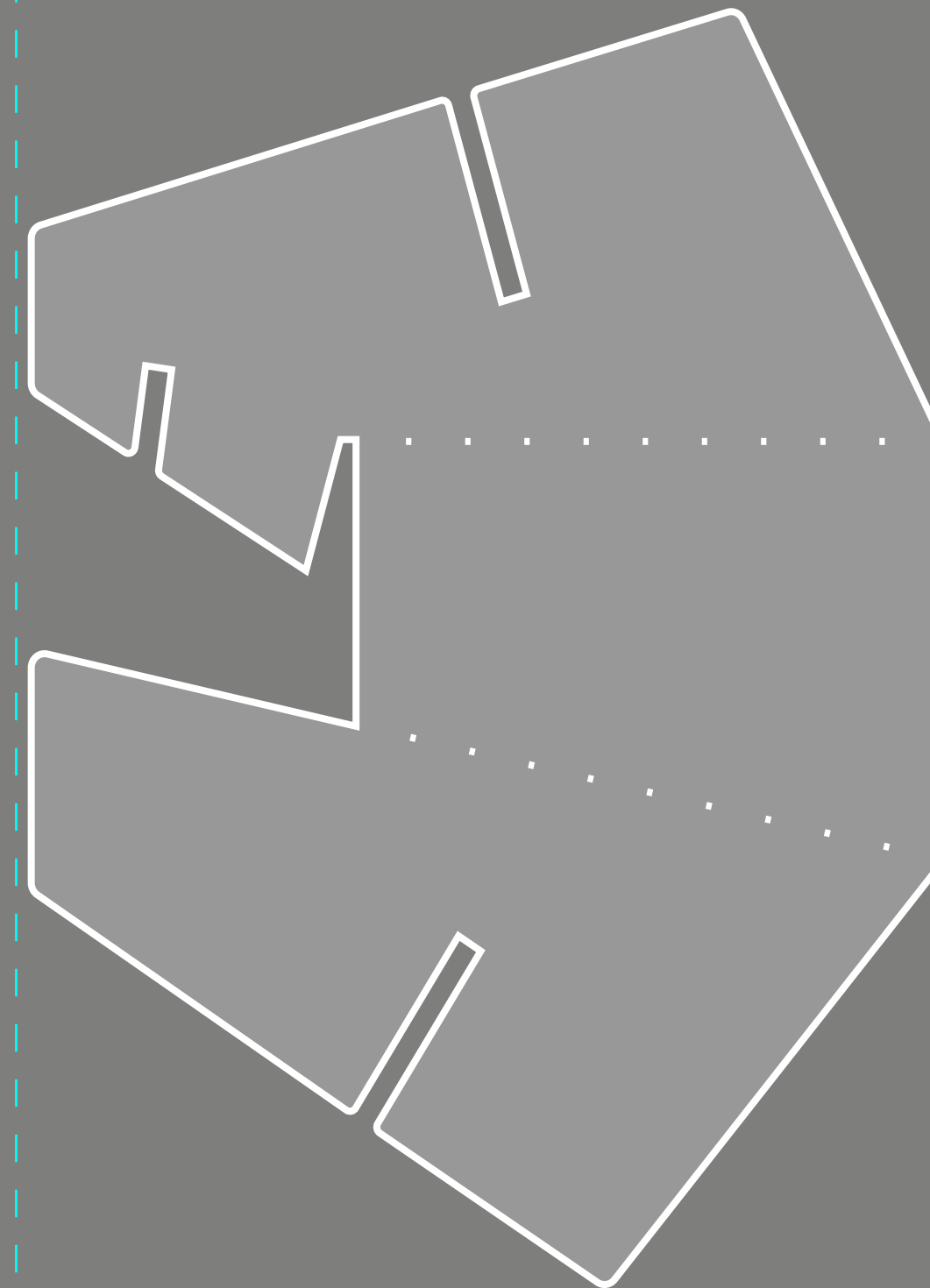
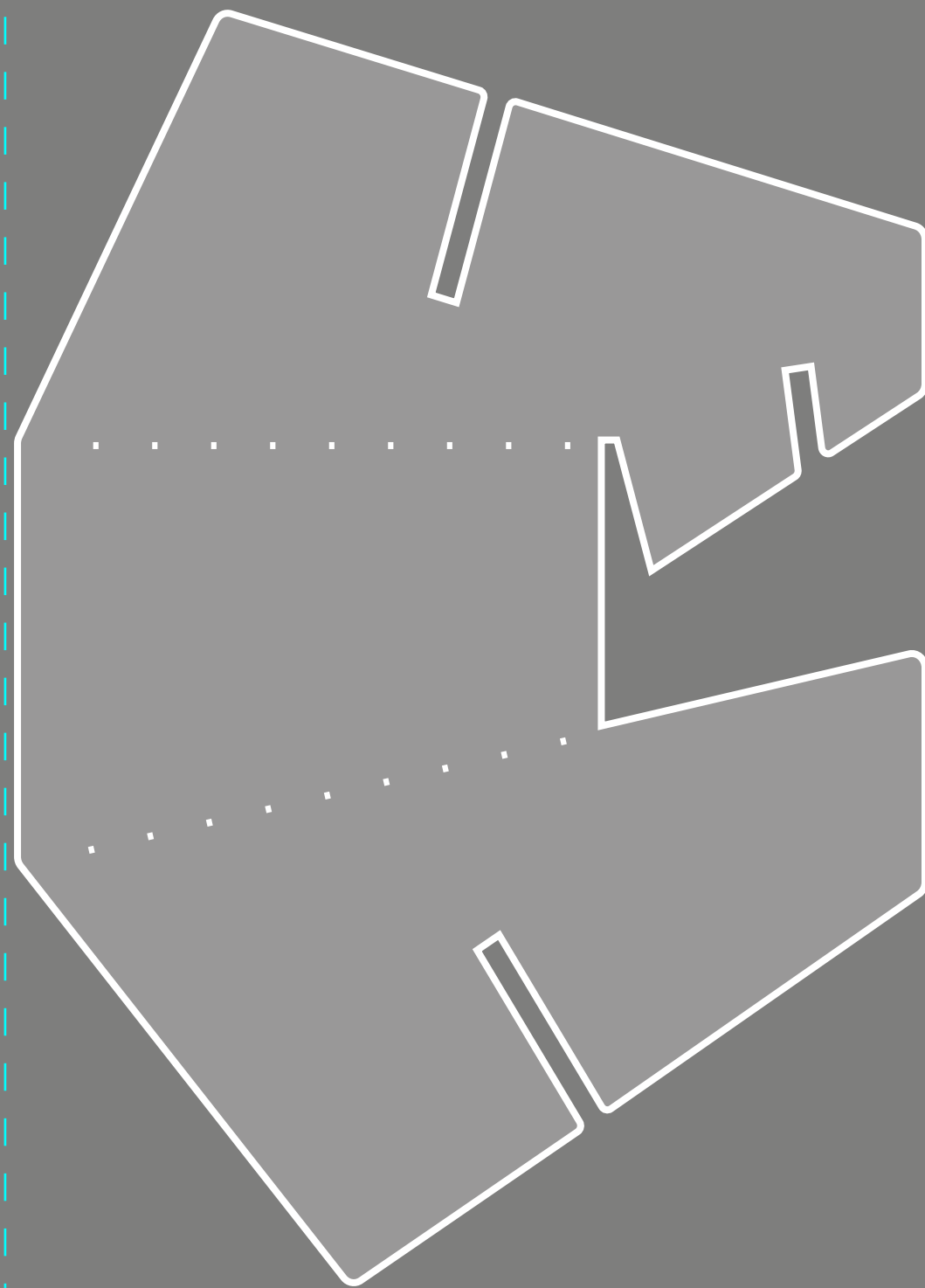

**konštrukcia využíva 4 formáty B1**

+ štandardizovaný formát deskového materiálu

**technológia**

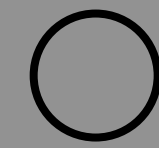

**Zund – rezací nôž**

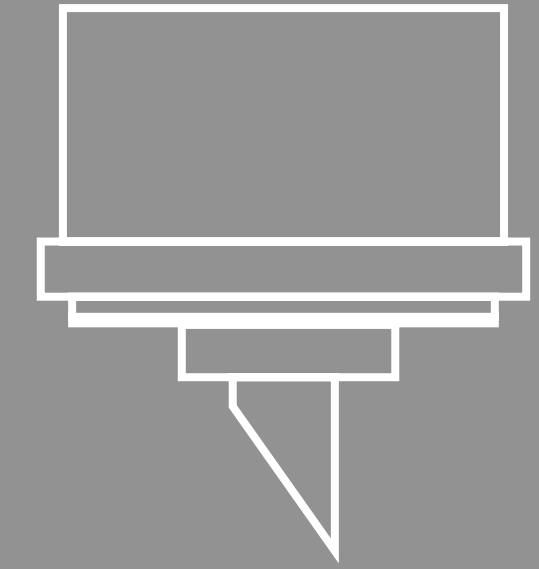

**materiál**

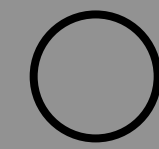

**2 x 6 mm, 5 vrstvá  
vlnitá lepenka**

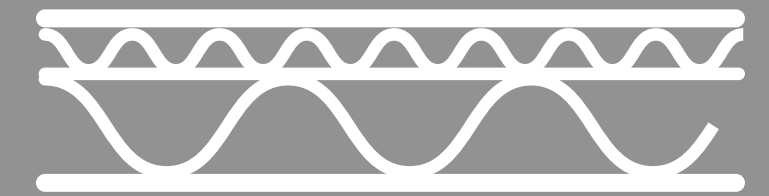

**+**

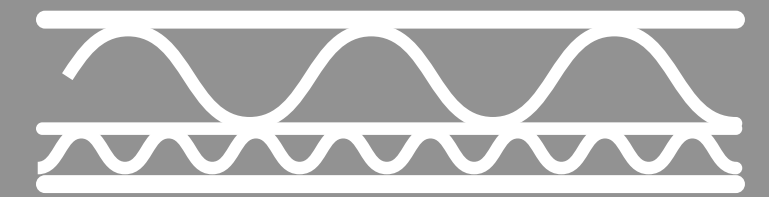

**čas výroby 1 ks**

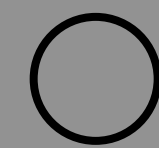

**2 h**

**spotreba materiálu**

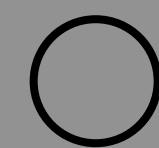

**3,5 m<sup>2</sup>**

**predajná cena**

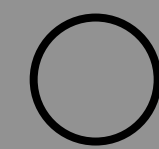

**400 Kč**





**Ďakujem za pozornosť**

Dedík / ADE / 2017